

# MULTIPLE NOZZLE SPRAY DESUPERHEATER

MNSD-V & MNSD-U

COPEL VULCAN®



Celeros Flow Technology is a full-lifecycle partner for sustainable flow technology solutions, from initial design and installation of equipment to after sales support, throughout an asset's full operational lifecycle.

Celeros FT's products and technologies support many different sources of power generation, including coal and natural gas, nuclear, solar and geothermal. The company's innovative product portfolio, containing many energy efficient products, includes valves, pumps and filters.

Celeros FT manufactures the Copes-Vulcan general service and severe duty control valves, desuperheaters and direct steam converting valves, as well as reciprocating, centrifugal, multi-stage and screw type pumps, filtration systems and strainers.



## MULTIPLE NOZZLE SPRAY DESUPERHEATER (MNSD)

### OFFERS HIGH TEMPERATURE CAPABILITIES AND LOW COOLANT CLASS V LEAKAGE RATING

The Multiple Nozzle Spray Desuperheater offers optimum performance and rangeability in a variable spray tube design. The Model MNSD-V fills the performance gap between the limited capability of a simple mechanical spray type desuperheater and the virtually unlimited capability of Copes-Vulcan's Variable Orifice Desuperheater (Model VO). And, the MNSD-V offers high temperature capabilities and low class V leakage rating.

### FEATURES

- Temperature control to within 15°F (8°C) of saturation with the ability to hold set point within a tolerance of 10°F (6°C)
- Standard maximum available Cv of 10.5 (Kv of 8.9)
- Waterflow turndown of 150:1 or higher
- User friendly design — nozzles and trim assembly can be removed without disconnecting actuator
- No need for separate cooling water control valve
- Designed for applications with temperatures up to 1150°F (620°C)
- Available in standard classes 600, 900, 1500 and 2500 per ANSI B16.5
- Cooling water inlet pressures up to 3500 psig (24 MPag) allowable standard (higher pressures allowable per application)

- ANSI Class V FCI 70-2 tight shutoff capability
- Suitable for vertical or horizontal installation
- Standard ANSI connections: 3" (80mm) raised face flange (steam) 1.5" (40mm) raised face flange (water)
- Designed for high thermal fatigue life

Many applications require turndowns in excess of that offered by a simple mechanical spray desuperheater. Many applications require turndowns in excess of that offered by a simple mechanical spray desuperheater but do not necessarily warrant the expense or require the additional refinements offered by the Variable Orifice Desuperheater. Many of these intermediate duties can be met with a steam atomizing type desuperheater (SA-35), but atomizing steam is often not available, or the additional installation and operational expense is not economically justified. The Multiple Nozzle Spray Desuperheater has been designed for these applications.

The MNSD-V Desuperheater automatically controls the cooling water flow with the ability to modulate and shutoff. A separate cooling water control valve is not required as the unit itself controls variations in required coolant flow. Unlike competitive models that can only operate with relatively low water inlet pressures, the MNSD-V can be supplied to accept cooling water inlet pressures to 3500 psig (24 MPag).



### DESIGN AND PRINCIPLE OF OPERATION

The MNSD-V consists essentially of a cage-guided plug situated within the nozzle tube just behind the discharge nozzles.

The nozzle tube assembly fits up into the bore of the mounting flange and is locked in place with a threaded ring. This junction enables the cooling water inlet connection to orient in any direction relative to the position of the discharge nozzle spray at time of assembly. \* Field alteration of this orientation is also quite easy.

The MNSD-V Desuperheater head offers a means of mounting the unit to a companion flange on the main header. It also provides an inlet connection for the cooling water, a gland assembly for stem sealing and a mounting arrangement for the dependable Copes-Vulcan Model 700 Diaphragm Actuator.



\*Standard orientation is cooling water inlet directly opposite spray outlet.

### TYPICAL PRODUCT APPLICATIONS

Power



Chemical

Refineries



Pulp & Paper



### DISCHARGE NOZZLES

The multiple nozzle arrangement located near the end of the nozzle tube is composed of up to 22 uniquely designed discharge nozzles arranged in an overlapping manner to offer an extremely smooth flow characteristic. The quantity, individual sizes, and placement of the discharge nozzles are selected for each application to optimize capacity, maximize controllability and rangeability.



### COOLING WATER

The cooling water is admitted to the nozzle tube assembly through the branch in the mounting head.

It reaches the lower portion of the nozzle tube assembly as the plug exposes the nozzles. With the plug seated, no cooling water can reach the discharge nozzles.

As the plug is extended by the actuator under the signals of the temperature control loop, cooling water is throttled at each exposed nozzle through flow characterization slots located just prior to the discharge nozzles.

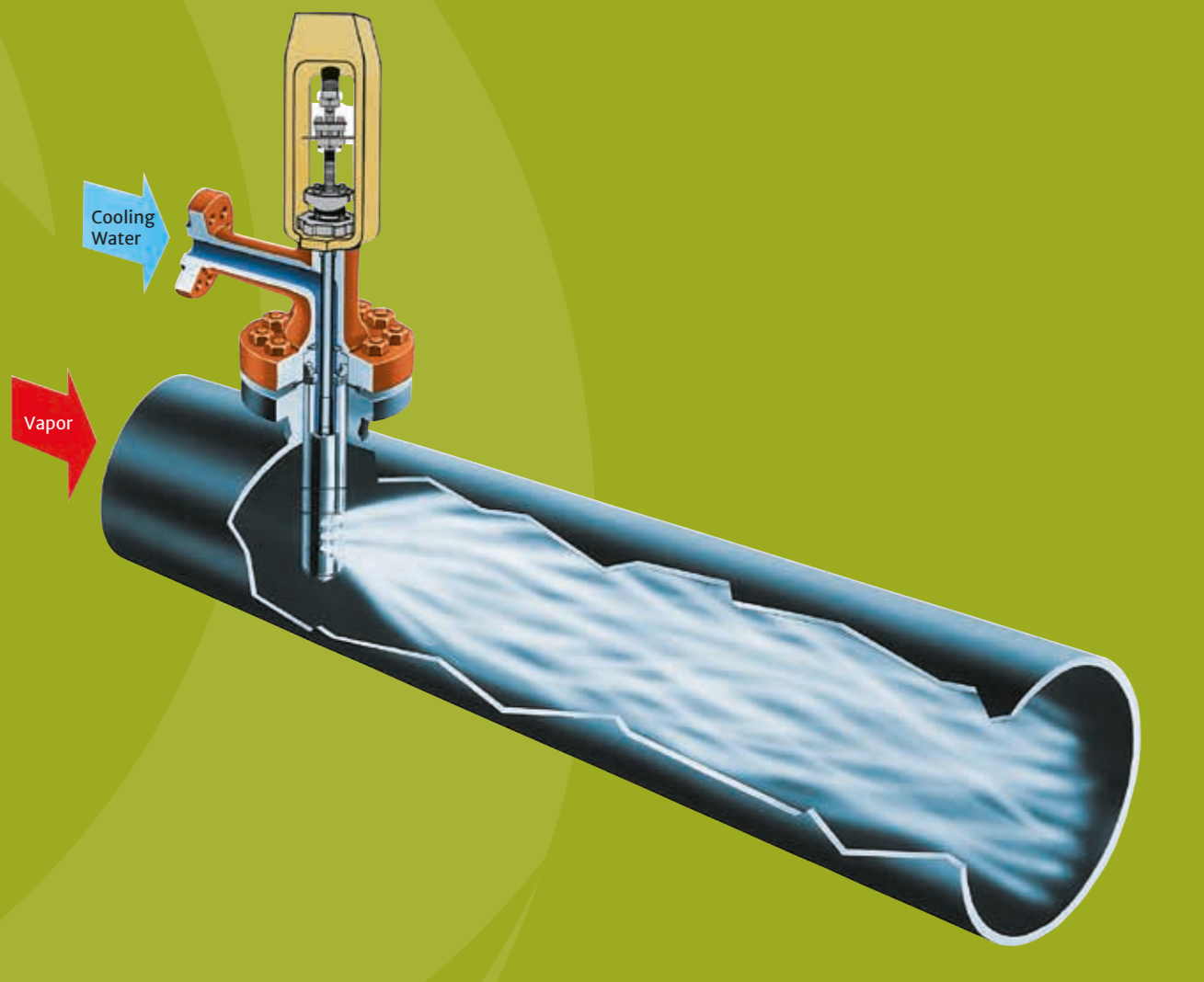

### OPTIMUM DESUPERHEATER EFFICIENCY

The cooling water then passes through specially designed swirl discharge nozzles. Most of the energy available from the differential pressure between the cooling medium and the main header is expended while expanded through the nozzles which intensifies mechanical atomization. The resulting soft, misty spray has a very low exit velocity. This promotes rapid absorption and optimum desuperheater efficiency, even at very low flow rates.

The spray from the first discharge nozzle, and typically the smallest, is quickly dispersed within an average of 3' (1m) from the point of discharge. As the plug continues to modulate open, a swirling interaction of the various discharge nozzle sprays maintains a narrow cone shaped pattern. This keeps the water droplets in the center of the header where the line turbulence is the greatest allowing for faster, more complete absorption of the cooling medium.

### MATERIALS OF CONSTRUCTION

#### SIZING SELECTION

The MNSD-V/MNSD-U and all Copes-Vulcan desuperheaters can be sized by Copes-Vulcan or an authorized sales representative using SmartSize computer sizing program to assure correct application.

ITEM	MATERIAL
BODY CASTING	ASTM A217, Grade WC6
	ASTM A217, Grade WC9
	ASTM A217, Grade C12A
	ASTM A351, Grade CF8M
CAGE & TORQUE RING	ASTM A565, Grade 616, Type 422, Hardened
EXTENSION LEG	ASTM A182, Grade F22
	ASTM A565, Grade 616, Type 422, Hardened
RETAINING RING: (FOR SPRAY TUBE ASSEMBLY)	ASTM A479, Type 410, Hardened
PLUG	ASTM A565, Grade 616, Type 422, Hardened
ORIFICE DISC	ASTM A276, Type 420, Hardened
SWIRL DISC	300 Series Stainless Steel
SPACER	ASTM A479, Type 304
SEAL RINGS	Nitronic 60
ROLL PIN	400 Series Stainless Steel
SEAL (BODY/EXTENSION LEG) (CAGE/EXTENSION LEG)	Graphite with 316 SS
SEAT	UNS R3006 Stellite 6
STEM	ASTM A276, Type 316, Cond. B



### INSTALLATION RECOMMENDATIONS

For optimum control and performance, apply the following guidelines:

- If the difference between the cooling medium and the header vapor temperature is greater than 450°F (250°C), and if the main header wall thickness is greater than .5" (12mm), a thermal liner is recommended.
- For applications where unfiltered cooling medium is used, a 30 mesh strainer is recommended for installation upstream of the cooling medium inlet.

### TYPICAL INFORMATION REQUIRED TO SIZE:

- Process steam flow rates
- Process steam pressure
- Process steam temperature (superheated)
- Desired process steam temperature (desuperheated)
- Available cooling water pressure
- Available cooling water temperature
- Process steam line size and schedule

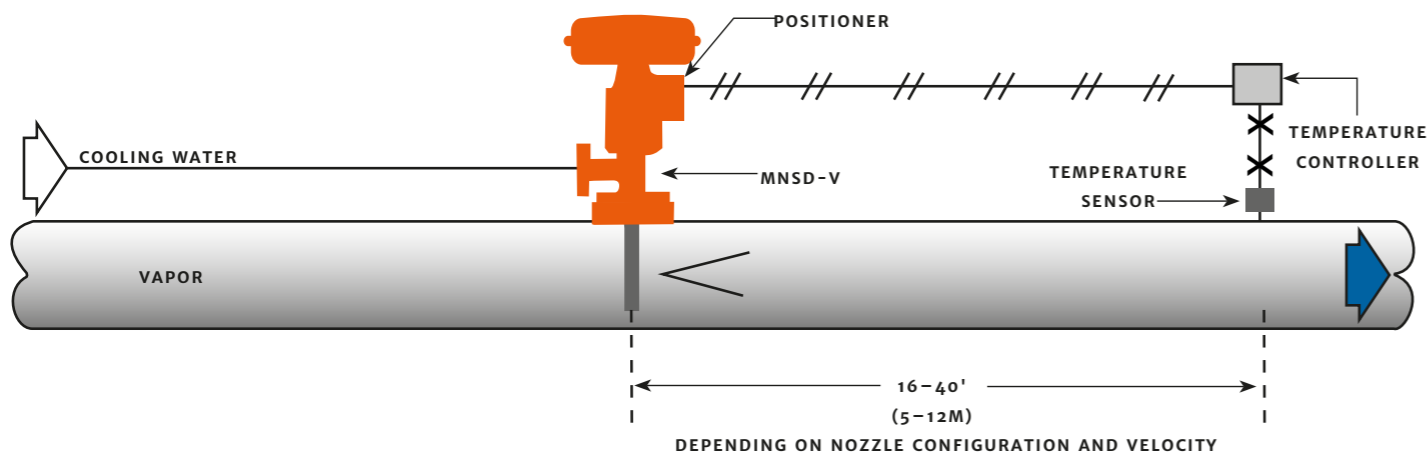

### DIMENSIONS

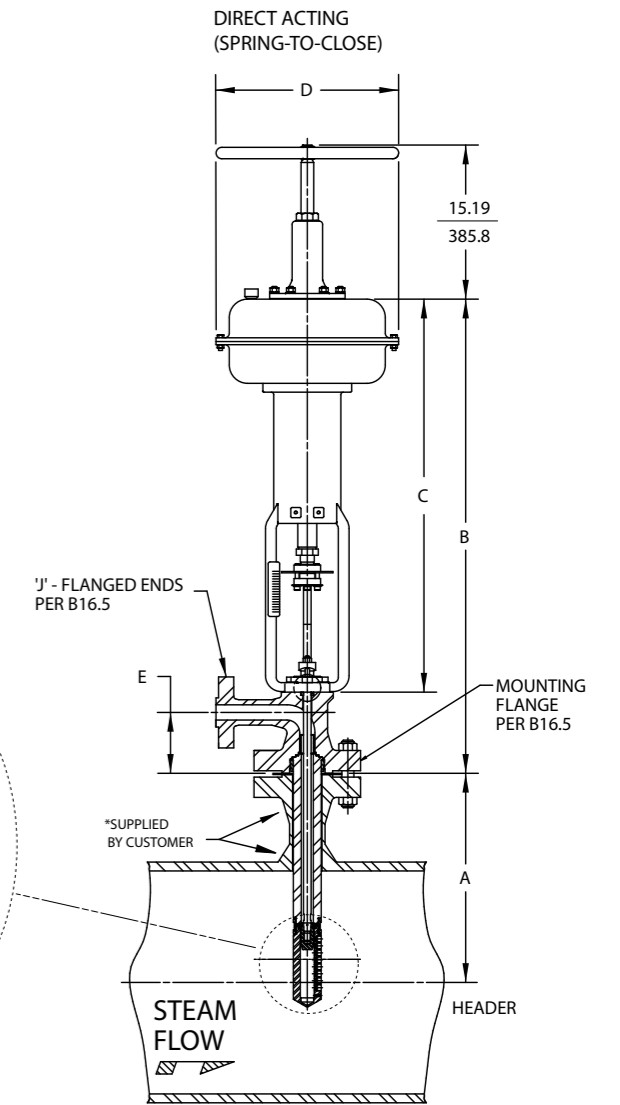
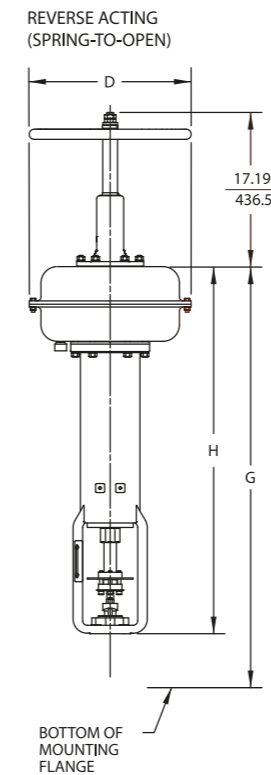

### 3" (80MM) MOUNTING FLANGE SIZE

MAIN HEADER SIZE	A
6" (150mm)	12.06 306
8" (200mm)	13.06 332
10" (250mm)	14.12 358
12" (300mm)	15.12 384
14" (350mm)	15.75 400
16" (400mm)	16.75 425.4
18" (450mm)	17.5 451
20" (500mm)	18.75 477
22" (550mm)	19.75 502
24" (600mm)	20.75 527
30" (750mm)	23.63 600

### 3" (80MM) MODEL 700 CLASS 150 THROUGH 1500

ACTUATOR SIZE	DIMENSIONS							
	B	C	D	E	F	G	H	J FLANGE
160	39.91 998.5	31.31 795	18.00 457	6 152	9 229	39.31 998	32.38 822	1.5 40
160L	40.37 1025.4	39.75 1010	18.00 457	6 152	9 229	47.75 1213	40.81 1037	1.5 40

### 3" (80MM) MODEL 700 CLASS 2500

ACTUATOR SIZE	DIMENSIONS							
	B	C	D	E	F	G	H	J FLANGE
160	40.31 10245	31.31 795	18.00 457	7 178	9.5 241	41.37 1051	32.38 822	1.5 40
160L	41.37 1051	39.75 1010	18.00 457	7 178	9.5 241	49.81 1265	40.81 1037	1.5 40





## MNSD-V & MNSD-U MULTIPLE NOZZLE SPRAY DESUPERHEATER

- | SPEED
- | EXCELLENCE
- | PARTNERSHIP

 COPES VULCAN®



**KV CONTROLS**  
Control & Isolation Valves

46 Mercury Street  
Naledi Industrial Park  
Vaalpark  
Tel: +27 (0) 16 100 4592  
[www.kvcontrols.co.za](http://www.kvcontrols.co.za)

KV Controls (PTY) Ltd. Reg No: 2016/378940/07

Road Two  
Industrial Estate  
Winsford, Cheshire  
CW7 3QL  
England

P: +44 1606 552041  
F: +44 1606 558275  
E: [copeinquires@celerosft.com](mailto:copeinquires@celerosft.com)

*Celeros Flow Technology reserves the right to incorporate our latest design and material changes without notice or obligation. Design features, materials of construction, and dimensional data, as described in this bulletin, are provided for your information only and should not be relied upon unless confirmed in writing. Please contact your local sales representative for product availability in your region. For more information, visit [www.celerosft.com](http://www.celerosft.com).*  
CV\_MNSD-Desuperheater\_419\_PB\_A4\_ Version 01/2021 Issued 02/2021  
COPYRIGHT © 2021 CELEROS, Inc.

[www.celerosft.com](http://www.celerosft.com)