



HPY

HPY Series Pneumatic Actuator



Structure Features

Modular Design

HPY series actuators adopt a highly modular design concept and are divided into cylinder module (hydraulic cylinder module), box module and spring module to simplify field configuration. Users can flexibly choose the mode of action according to the actual use requirements, with strong mutuality and universality. It can easily realize the combination and replacement of single and double acting, manual operation and other modules without the need of special tools. Cylinder or hydraulic cylinder module can be configured on one side or on both sides.

High Precision and High Strength with Inner Oriented Design

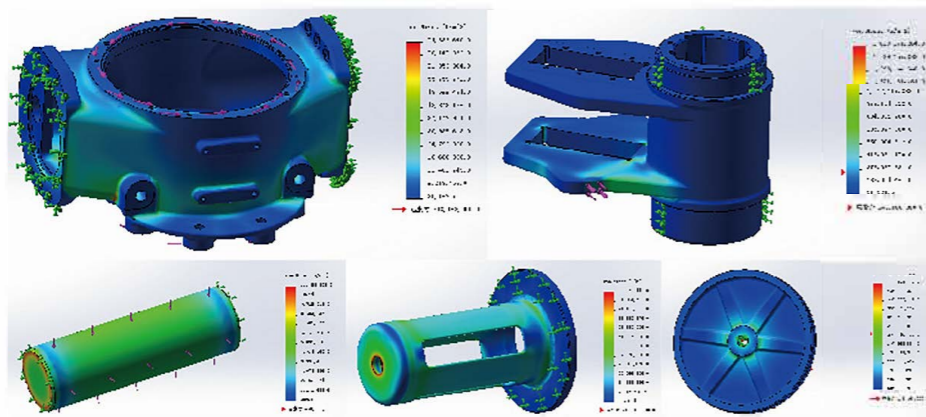

The center body and yoke are made of ductile iron or cast steel, the yoke pin is made of alloy steel with excellent mechanical performance, and the adjustment bolts and fastening bolts of flange on both sides of the center body are of class 12.9 to ensure sufficient strength. The processing of the center body is one-step molding on four sides by high precision horizontal machining center for high transmission accuracy.

Yoke Pin's Plane Transmission Structure

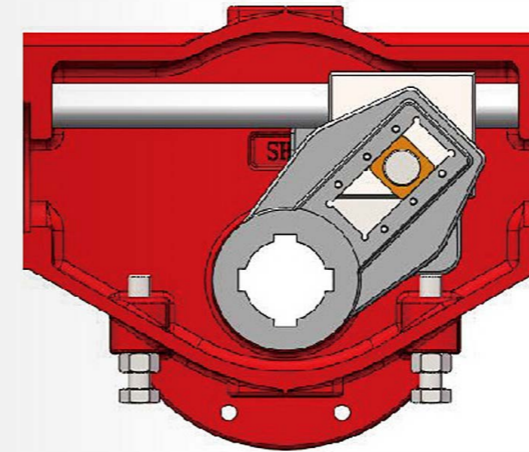

The transmission of the yoke pin is equipped with square copper slider structure, which ensures smooth transmission. The surface contact with the yoke can better protect the working face and extend the service life. The wear resistance and self-lubrication of aluminum bronze sliders can effectively improve the transmission efficiency.

Air connection in the front, lifting hole on the top.



Air connections are spread in the front and in the back symmetrically, convenient for installing attachment panels and connecting pipelines. Two air connections can meet clients' demands for motion speeds. A variety of air interfaces for pipe threads are available. The lifting rings are set according to the whole center of gravity, which is convenient for the lifting of the actuator. The rings are treated with dacrose anti-corrosion and lighting process.



Performance and Features

Working Media and Pressure

The working medium is usually dry compressed air, inert gas or anti-wear hydraulic oil.

When the working medium is gas

Working pressure: 3-10bar

Maximum service pressure: 10bar

Recommended pressure: 4-6bar

Please consult our company when the medium is liquid.

Working Temperature and Sealing Performance

Operating temperatures:

Standard -20°C to +80°C

High Temperature -20°C to +150°C

Low Temperature -40°C to +80°C

The cylinder inner wall and piston rod surface honing and hard chrome plating, combined with the dynamic sealing design of star ring, greatly improve the sealing performance of the product.

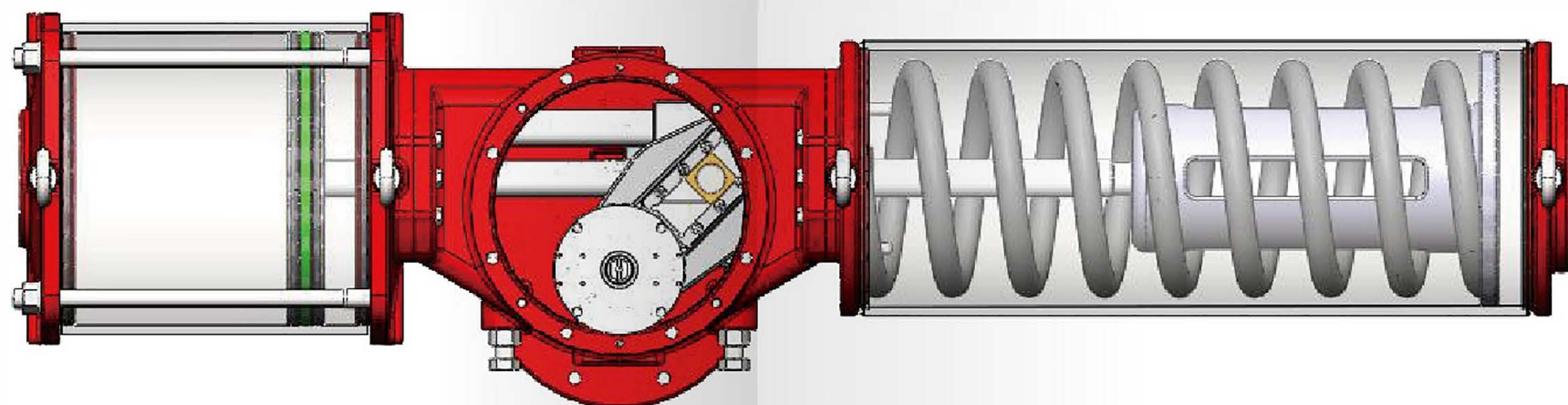

A Route and an Adjusting Scale

Standard stroke 0-90°, 0-60° and other non-standard stroke can be customized; Bi-directional travel stops, adjustable from -6° to 96°. Full stroke adjustable can be customized. By adding auxiliary Chambers, the three-position structure can be customized to achieve the requirements of 0-30° -90° adjustable or other intermediate angles.

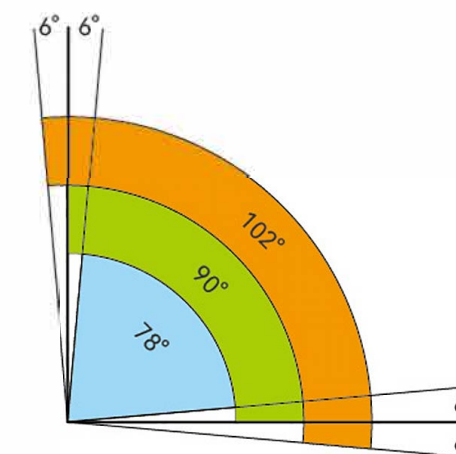

Standard Interface

Output shaft conforms to NAMUR standard, which facilitates the installation of limit switch, positioner and other accessories; the flange is strictly in accordance with ISO5211 standard. It's equipped with anti-rotating pin hole, drainage channel.

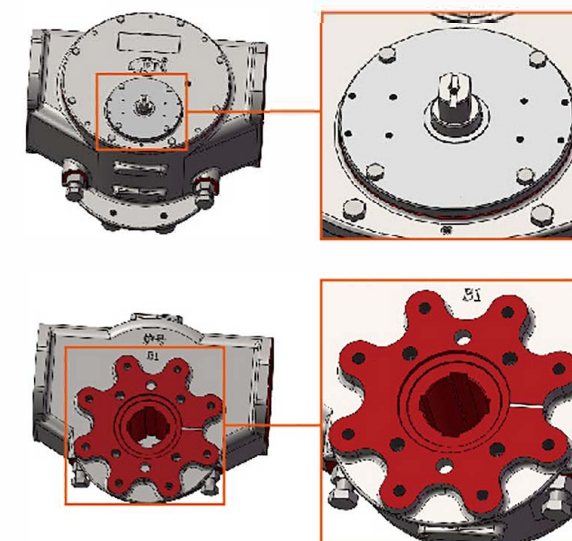

Parts and Materials of HPY Light Load Series

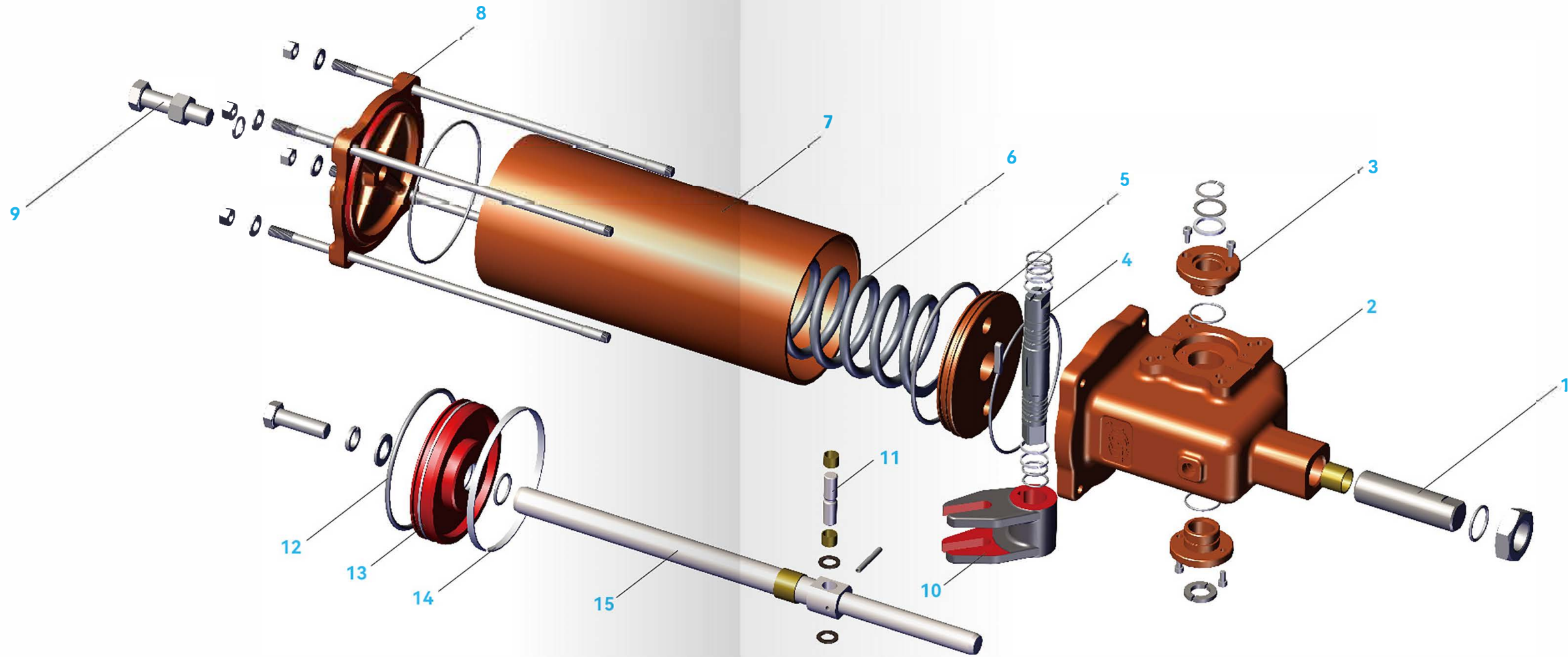

Item	Name	Qty.	Material
1	Limit screw sleeve	1	Stainless Steel
2	Centre Body	1	Cast Aluminum Alloy
3	Bushing	n	Aluminum Alloy
4	Pinion	1	Carbon Steel
5	Adapter Plate	1	Aluminum Alloy
6	Spring	1	Spring Steel
7	Cylinder Tube	1	Carbon Steel+Hard Chrome Plating
8	Cover	1	Cast Aluminum Alloy
9	Limit bolt	1	Stainless Steel

Item	Name	Qty.	Material
10	Yoke	1	Ductile Iron
11	Pin	1	Alloy Steel
12	O-Ring	n	Rubber
13	Piston	1	Aluminum Alloy
14	Guide Ring Piston	1	Resin
15	Guide	1	Alloy Steel

Output Torque of HPY-B Series Double Acting Actuator

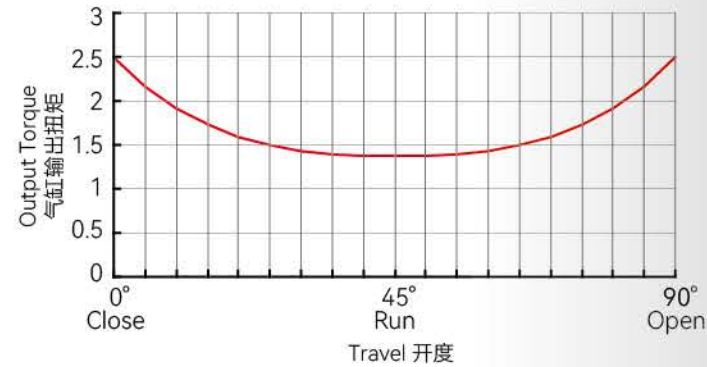

Output Torque of HPY-C Series Double Acting Actuator

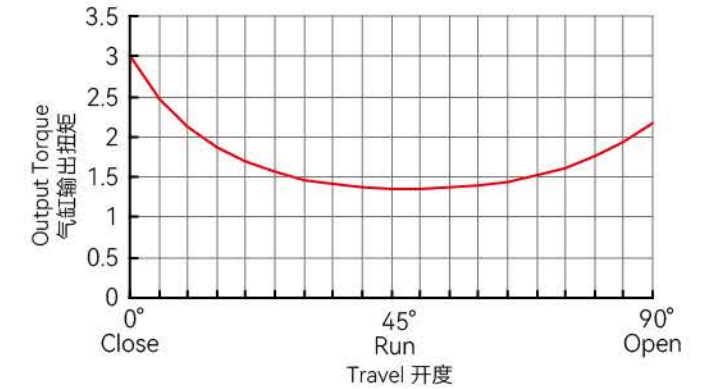

Model	3.5 Bar			4 Bar			5 Bar			6Bar		
	0°	45°	90°	0°	45°	90°	0°	45°	90°	0°	45°	90°
HPY-B06-201-DA	1286	679	1286	1471	776	1471	1838	970	1838	2205	1164	2205
HPY-B08-221-DA	2036	1074	2036	2327	1228	2327	2908	1535	2908	3489	1842	3489
HPY-B08-251-DA	2629	1387	2629	3004	1586	3004	3755	1982	3755	4506	2378	4506
HPY-B1-281-DA	3879	2047	3879	4433	2340	4433	5542	2925	5542	6650	3510	6650
HPY-B1-321-DA	5067	2674	5067	5791	3056	5791	7238	3820	7238	8686	4584	8686
HPY-B1-351-DA	6062	3199	6062	6927	3656	6927	8659	4570	8659			
HPY-B2-351-DA	7274	3839	7274	8312	4387	8312	10391	5484	10391	12469	6581	12469
HPY-B2-401-DA	9500	5014	9500	10858	5730	10858	13572	7163	13572	16286	8596	16286
HPY-B2-451-DA	12024	6346	12024	13741	7252	13741	17177	9065	17177			
HPY-B3-451-DA	14529	7668	14529	16604	8763	16604	20755	10954	20755	24907	13145	24907
HPY-B3-501-DA	17936	9466	17936	20499	10819	20499	25624	13524	25624	30749	16228	30749
HPY-B3-561-DA	22500	11875	22500	25714	13571	25714	32143	16964	32143	38570	20357	38570
HPY-B3-601-DA	25828	13632	25828	29518	15579	29518	36898	19474	36898			
HPY-B4-561-DA	27155	14332	27155	31034	16379	31034	38793	20474	38793	46551	24568	46551
HPY-B4-601-DA	31172	16452	31172	35626	18802	35626	44532	23503	44532	53438	28204	53438
HPY-B4-631-DA	34367	18138	34367	39277	20729	39277	49097	25912	49097	58916	31094	58916
HPY-B4-701-DA	42430	22393	42430	48490	25592	48490	60613	31990	60613			
HPY-B4-502-DA	43295	22850	43295	49480	26115	49480	61850	32643	61850			
HPY-B4-562-DA	54310	28663	54310	62068	32758	62068						
HPY-B4-801-DA	55418	29248	55418	63335	33427	63335						
HPY-B5-701-DA	50430	26616	50430	57634	30418	57634	72043	38023	72043	86451	45627	86451
HPY-B5-562-DA	64551	34068	64551	73772	38935	73772	92215	48669	92215	110658	58403	110658
HPY-B5-801-DA	66234	34947	66234	75696	39939	75696	94620	49924	94620	113544	59909	113544
HPY-B5-602-DA	74102	39109	74102	84687	44696	84687	105859	55870	105859	127031	67044	127031
HPY-B5-632-DA	81697	43118	81697	93368	49277	93368	116709	61597	116709			
HPY-B5-901-DA	83827	44229	83827	95802	50548	95802	119753	63185	119753			
HPY-B5-702-DA	100860	53232	100860	115268	60836	115268						
HPY-B5-1001-DA	103490	54604	103490	118274	62404	118274						
HPY-B6-901-DA	112844	59539	112844	128965	68045	128965	169222	85056	161206	193437	102062	193437
HPY-B6-702-DA	135773	71658	135773	155170	81895	155170	193962	102369	193962	232754	122843	232754
HPY-B6-1001-DA	139314	73505	139314	159216	84006	159216	199020	105008	199020	238824	126009	238824
HPY-B6-802-DA	177337	93594	177337	202670	106965	202670	253337	133706	253337			
HPY-B6-902-DA	225689	119079	225689	257930	136090	257930						

Model	3.5 Bar			4 Bar			5 Bar			6Bar		
	0°	45°	90°	0°	45°	90°	0°	45°	90°	0°	45°	90°
HPY-C06-201-DA	1540	676	1080	1760	772	1234	2199	965	1543			
HPY-C08-221-DA	2436	1069	1709	2784	1221	1952	3480	1527	2440	4176	1832	2929
HPY-C08-251-DA	3145	1380	2206	3595	1577	2521	4494	1971	3152			
HPY-C1-281-DA	4642	2036	3256	5305	2328	3720	6631	2910	4651	7958	3492	5581
HPY-C1-321-DA	6064	2660	4253	6930	3040	4859	8662	3800	6075			
HPY-C1-351-DA	7254	3182	5087	8289	3636	5814						
HPY-C2-351-DA	8704	3819	6105	9948	4364	6977	12434	5455	8720	14922	6546	10464
HPY-C2-401-DA	11369	4988	7973	12993	5700	9112	16241	7125	11390	19489	8550	13668
HPY-C2-451-DA	14389	6313	10091	16445	7214	11533						
HPY-C3-451-DA	17386	7627	12193	19870	8718	13935	24837	10897	17419	29805	13076	20902
HPY-C3-501-DA	21464	9417	15054	24531	10762	17204	30663	13452	21505	36796	16142	25806
HPY-C3-561-DA	26925	11813	18883	30772	13499	21581						
HPY-C3-601-DA	30909	13560	21677	35324	15497	24773						
HPY-C4-561-DA	32496	14256	22789	37138	16293	26046	46422	20366	32557	55707	24440	39069
HPY-C4-601-DA	37303	16366	26161	42633	18703	29899	53291	23379	37374	63949	28055	44849
HPY-C4-631-DA	41128	18043	28843	47003	20621	32964	58753	25776	41205			
HPY-C4-701-DA	50775	22276	35609	58028	25457	40696						
HPY-C4-502-DA	51810	22730	36336	59213	25977	41527						
HPY-C5-701-DA	60688	26476	42564	69358	30258	48655	86699	37823	60819	104037	45387	72982
HPY-C5-562-DA	77682	33889	54493	88779	38730	62278	110973	48413	77848	133168	58095	93417
HPY-C5-801-DA	79267	34580	55605	90590	39521	63549	113238	49401	79436	135885	58336	95323
HPY-C5-602-DA	89175	38903	62556	101914	44460	71493	127393	55576	89365			
HPY-C5-632-DA	98315	42891	68968	112360	49018	78821						
HPY-C5-901-DA	100882	43997	70787	115294	50284	80899						
HPY-C6-801-DA	106705	46551	74854	121948	53201	85547	152436	66501	106933	182923	79801	128320
HPY-C6-901-DA	135048	58916	94737	154341	67332	108270	192926	84165	135337	231511	100999	162405
HPY-C6-702-DA	163392	71281	114619	186734	81464	130993	233417	101830	163742			
HPY-C6-1001-DA	167657	73121	117642	191609	83567	134448	236849	104458	168060			
HPY-C6-802-DA	213409	93101	149706	243896	106402	171093						