PNEUMATIC ACTUATOR

New DR/SC-Series 00015 to 05000

KVRP



ISO9001-2000认证





CONTENTS

Specification and Type Catalogue -----	01
Parts, Materials and Corrosion Protection -----	02
Operating Principles -----	03
Pattern Selection and Data -----	04
Output Torque -----	05
Configuration and Connection Size -----	07
Full Stroke Modulating Actuator -----	09
120°-180°double Acting Actuator -----	10
3-position Pneumatic Actuator -----	11
Accessories and Pneumatic Valve -----	15
Brief Introduction on The Company -----	16
Design and Manufacture -----	17



New Pneumatic Valve Actuator of Series DR/SC

The new dr/sc pneumatic actuator of rack and gear wheel type is manufactured by shanghai shst meter valve co., ltd adopting the latest technique both home and abroad. Cad based 3d modeling is also applied to optimize the design of the products and to make innovation on the design as well. The aspect of the product is modern, compact and good looking. Built with new materials and new process, the quality of the products could be guaranteed as well as the performance. Moreover more types of products are available to benefit customers. All the products are completely designed and manufactured in according to the latest international standard specification of technology to meet the requirement now and in future.

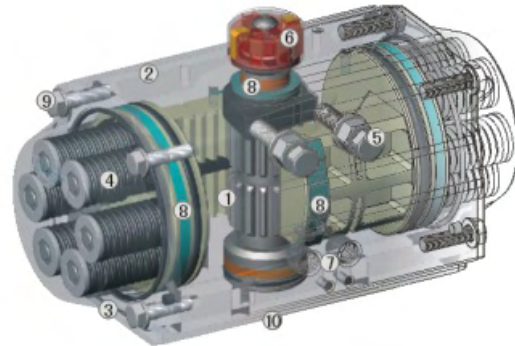

- ① The rack, gear wheel and the two pistons are designed in symmetric structure to perform stably and rapidly with high accuracy and high power output. The rotation in the inverse direction can be performed by simply changing the assembling location of the pistons.
- ② The extruded cylinder body is made of high quality stainless steel with fine machined socket and hard anodized outer surface (teflon coat + anodisation would be provided at special occasion) to prolong the service life and lower the coefficient of friction.
- ③ One-piece design is adopted. All type of single acting actuators and double acting actuators are provided with same cylinder body and end cap. The acting module could be easily changed by installing or demounting springs.
- ④ Combined preload security group spring could be mounted or increased/decreased easily and safely during assembling or during in field usage.
- ⑤ The two sole adjusting screws at the side surface of the actuator which has been already installed on the valve could make the adjustment of location of the valve opening and closing more convenient and accurate. The special adjusting screws which are much longer would be provided if full stroke adjustment is needed.
- ⑥ Multifunctional location indicator, in field visible indicator and standard socket in accordance to VDI/VDE3845, NAMUR could be installed and export all the accessories such as limit switch cabinet, electric localizer and position sensor (JEELON, P+F, Turck).
- ⑦ The air supply interface is built according to NUMAR criterion. To the interface the NUMAR solenoid valve can be installed directly.
- ⑧ The composite material made bearing shell at the back of the rack, the deflector ring of the pistons as well as the bearing shaft of the output shaft are provided with more lubrication to protect them against the metal-metal friction. Thus, a prolong service life and the low friction could be guaranteed.
- ⑨ All the fasteners are made of stainless steel to be resistant to corrosion for a long time.
- ⑩ The pontes are built in accordance to latest version of ISO5211, DIN3337 (F03-F25) to guarantee the interchangeability and versatility of the products.

Type catalogue

DR 00150-090-F10-P22-10-HT-A

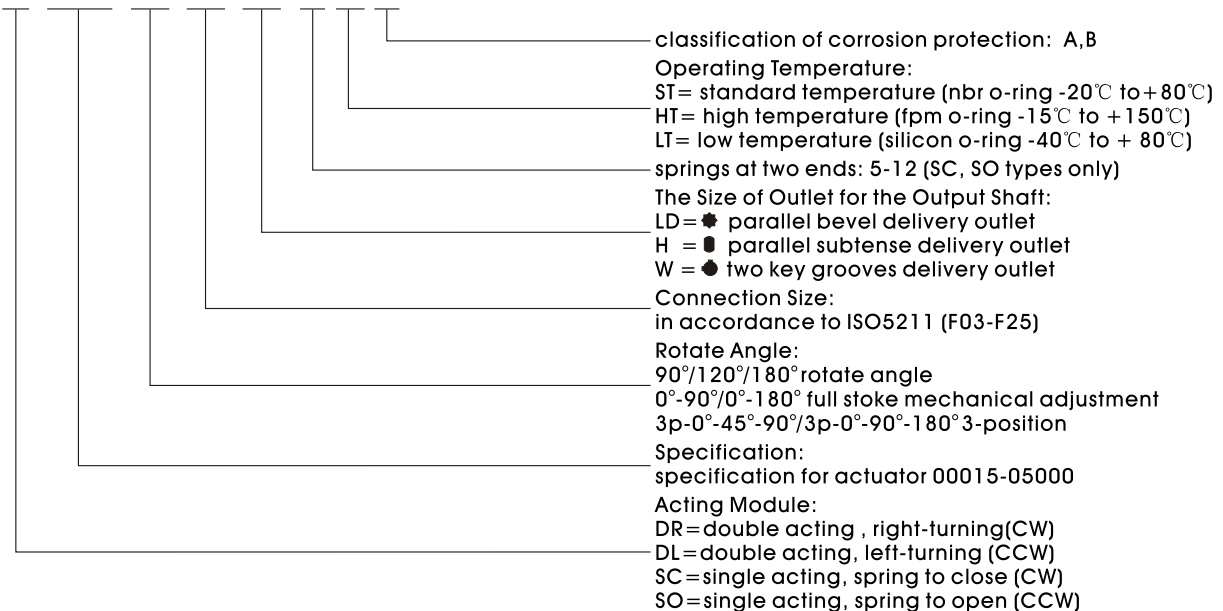



Components, Material and Corrosion Protection

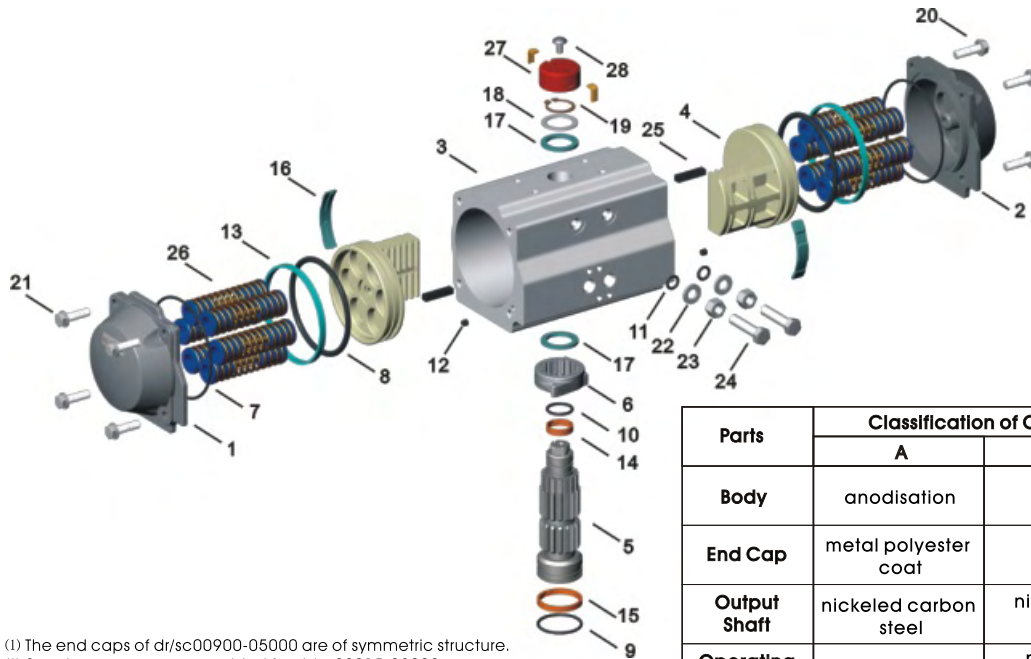

(1) The end caps of dr/sc00900-05000 are of symmetric structure.
 (2) 8 end cap screws are provided for dr/sc00015-02000
 While 12 for dr/sc03000-05000.

* the recommended parts for repair including the parts in the box of spare parts

Parts	Classification of Corrosion Protection	
	A	B
Body	anodisation	PTFE coat + anodisation
End Cap	metal polyester coat	PTFE coat
Output Shaft	nickeled carbon steel	nickeled carbon steel or stainless steel
Operating Environment	normal occasion	normal occasion or environment with low concentration of the acidity

Code of The Parts	Number for Each type	Name of The Parts	Standard Material	Material Selection
01	1 ⁽¹⁾	left end cap	aluminium die-cast alloys	stainless steel
02	1 ⁽¹⁾	right end cap	aluminium die-cast alloys	stainless steel
03	1	cylinder body	extruded aluminum alloy	stainless steel
04	2	piston	aluminium die-cast alloys	-----
05	1	output shaft	carbon-steel	stainless steel
06	1	adjusting cam	stainless steel	-----
07 *	2	O-ring (end cap)	nitrile rubber	FPM or silicon rubber
08 *	2	O-ring (piston)	nitrile rubber	FPM or silicon rubber
09 *	1	O-ring (bottom of output shaft)	nitrile rubber	FPM or silicon rubber
10 *	1	O-ring (top of output shaft)	nitrile rubber	FPM or silicon rubber
11 *	2	O-ring (adjusting screw)	nitrile rubber	FPM or silicon rubber
12 *	2	stopper end (cylinder body)	nitrile rubber	FPM or silicon rubber
13 *	2	bearing shaft (pistons)	fluorocarbon	-----
14 *	1	bearing shaft(top of output shaft)	PA66	-----
15 *	1	bearing shaft(bottom of output shaft)	PA66	-----
16 *	1	pilot bearing (back of the piston)	PA66	-----
17 *	2	thrust bearing (output shaft)	PA66	-----
18	2	filler piece (output shaft)	PA66	-----
19	1	elastic collar	stainless steel	-----
20	8/12/16 ⁽²⁾	end cap screw	stainless steel	-----
21	8/12/16 ⁽²⁾	end cap filler piece	stainless steel	-----
22	2	filler piece	stainless steel	-----
23	2	screw cap	stainless steel	-----
24	2	adjusting screw	stainless steel	-----
25	2	guide pad	PA66 + 30%FG	-----
26	5-12	spring subassembly	alloy spring steel	-----
27	1	location indicator	PP + 30%GF	-----
28	1	screw	stainless steel	-----



Operating Principle of DR(DL) Double Acting Type

The air source pressure comes into the cylinder body between the two pistons from air entrance (2) and pushes the pistons toward the end of the cylinder body. The air between the pistons and the ends of the cylinder body is released from air entrance (4). Meanwhile the racks of pistons rotate the output shaft anticlockwise (gear wheel) simultaneously, whereas if the air source pressure comes into the ends of the cylinder body from air entrance (4) and pushes the pistons toward each other with the air between two pistons released from air entrance (2), the output shaft (gear wheel) would be driven by the racks of the pistons simultaneously to rotate clockwise. (if the pistons are assembled in different direction from each other, the output shaft would turn out to rotate in inverse direction, namely the double acting reverse DL type)

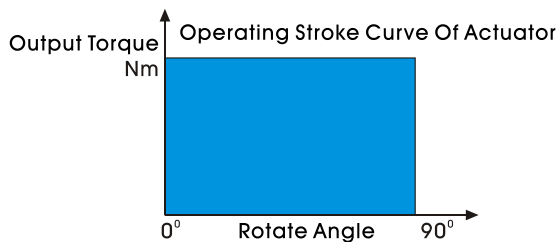
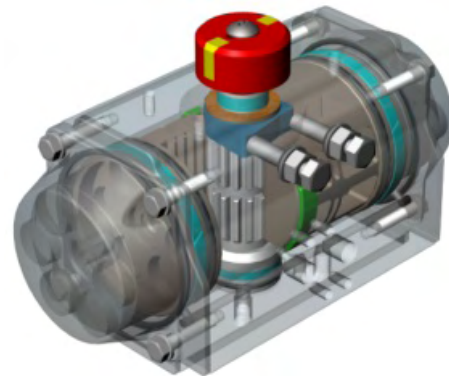
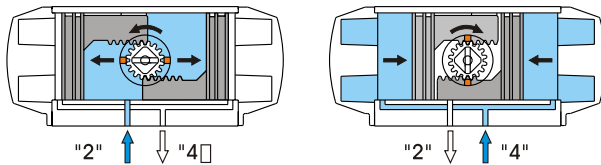

Operating Principle of SC(SO) Single Acting Type

The air source pressure comes into the cylinder body between the two pistons from air entrance (2) and pushes the pistons toward the end of the cylinder body while the springs at each ends inside the cylinder body is forced to shrink with the air between the pistons and the ends of the cylinder body released from air entrance (4). in the meantime, the racks of pistons drive the output shaft (gear wheel) simultaneously to rotate anticlockwise. After the direction of the air source pressure is reversed by the solenoid valve, the springs at each end begin to reset and the pistons are forced toward each other by the elasticity with the air between two pistons released from air entrance (2). Meanwhile the output shaft (gear wheel) would be driven by the racks of the pistons simultaneously to rotate clockwise. (if the pistons are assembled in different direction from each other, the output shaft would turn out to rotate in inverse direction when the springs reset, namely the single acting reverse SO type)

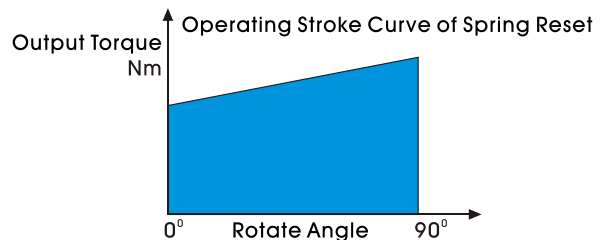
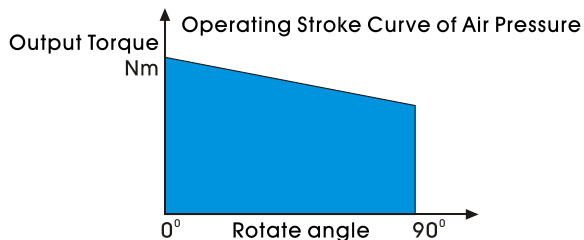
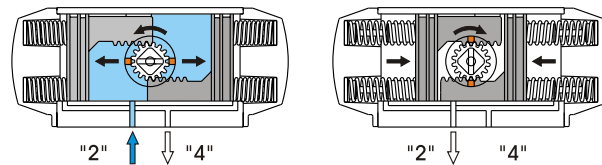
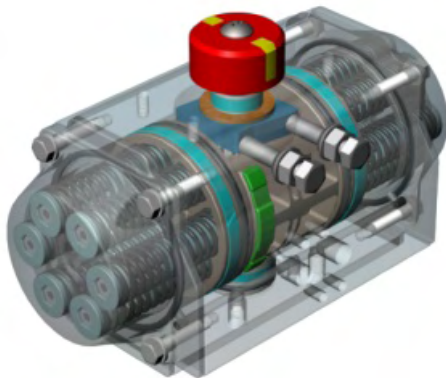



Pattern Selection of the Actuator

An increment should be added to the identified valve torque for safe when select the pattern of the pneumatic actuator. For vapor or non-lubricant liquor medium, the increment should be up to 25% of the valve torque, 30% for non-lubricant pasting liquor medium, 40% for non-lubricant dry air medium, 60% for non-lubricant particle medium delivered be air and 20% for lubricating clean medium with low friction respectively. (the safe increment above is recommended in theory for reference)

Sizing Example for Double-acting Actuator:

- * Published ball valve torque = 200 Nm
- * Operating medium = non-lubricated steam
- * Safety factor = 200 Nm + 25% = 250 Nm
- * Air supply pressure available = 5 bar
- * The double acting actuator that produces a minimum of 250 Nm at 5 bar is the DR00300 of 277 Nm according to the output torque table of the DR actuator.

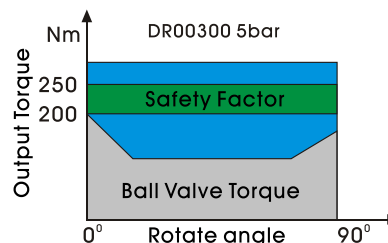

Sizing of A Single-acting Actuator:

- * Published butterfly valve torque = 100Nm
- * Operating medium = non-lubricated dry air
- * Safety factor = 100Nm + 40% = 140Nm
- * Air supply pressure available = 4.5 bar
- * The spring return actuator selected is the SC00450 (9 springs) with a most similar ending torque of 148Nm at 4.5 bar according to the SC output torque table. (The relative balance of torques between air supply pressure and spring return should be noted.)

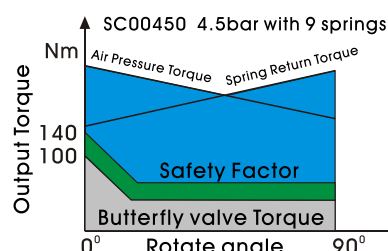

(A) The acting time of the actuator be tested under following conditions: (1) normal temperature (2) 90° stroke (3) caliber of the solenoid valve should be 4mm with the flow quantity of Qn400 L / min (4) inner diameter of the pipe should be 8mm (5) neutrally clean air (6) air source pressure at 5.5bar (7) actuator with no load
 PS: The acting time would change as one or more variables change in field test.
 (B) Suppose every SC actuator weighs as 10 springs, the increase/decrease weight of the actuator could be calculated by calculating the increase/decrease number of springs.

Relevant Data About The Actuator

TYPE	Max. Pressure	Rotate Angle	Operating Temperature	Stroke Adjustment per 1° laps	Diameter Φ(mm)	Ayr Volume(l)		Moving Time (sec)(A)		Weight (kg)(B)	
						Opening	Closing	Opening	Closing	Single	Spring
DR/SC00015	dry or lubricating clean compressed air 8bar	90° ± 4° or full stroke 0° ~ 90°	ST (standard) NBR O-ring -20 to +80 HT (high Temperature) FPM O-ring -15 to +150 LT (low Temperature) silicon O-ring -40 to +80	1/6	50	0.1	0.2	DR 0.2	DR 0.3	DR 1.1	-----
SC 0.3								SC 0.3	SC 1.2	0.01	
DR/SC00030				1/6	63	0.2	0.3	DR 0.3	DR 0.3	DR 1.6	-----
SC 0.3								SC 0.4	SC 1.8	0.02	
DR/SC00060				1/5	75	0.3	0.5	DR 0.3	DR 0.4	DR 2.8	-----
SC 0.4								SC 0.5	SC 3.2	0.03	
DR/SC00100				1/5	88	0.5	0.8	DR 0.4	DR 0.5	DR 4.0	-----
SC 0.5								SC 0.6	SC 4.7	0.06	
DR/SC00150				1/5	100	0.7	1.1	DR 0.5	DR 0.6	DR 5.9	-----
SC 0.7								SC 0.9	SC 6.7	0.07	
DR/SC00220				1/5	115	1.2	1.8	DR 0.7	DR 0.8	DR 8.5	-----
SC 0.9								SC 1.1	SC 10.0	0.13	
DR/SC00300				1/4	125	1.5	2.3	DR 0.9	DR 1.1	DR 10.7	-----
SC 1.2								SC 1.4	SC 12.5	0.16	
DR/SC00450				1/4	145	2.4	3.8	DR 1.2	DR 1.4	DR 15.5	-----
SC 1.5								SC 1.8	SC 18.3	0.25	
DR/SC00600	1/4	160	3.1	4.9	DR 1.5	DR 1.7	DR 19.5	-----			
SC 1.8					SC 2.1	SC 23.3	0.36				
DR/SC00900	1/4	180	4.3	6.9	DR 2.0	DR 2.2	DR 26.7	-----			
SC 2.4					SC 2.8	SC 32.8	0.50				
DR/SC01200	1/4	200	5.9	9.5	DR 2.7	DR 3.2	DR 35.6	-----			
SC 3.5					SC 4.0	SC 43.6	0.62				
DR/SC02000	1/4	240	10.0	15.2	DR 3.5	DR 4.0	DR 58.2	-----			
SC 4.1					SC 4.6	SC 71.0	1.12				
DR/SC03000	1/4	265	14.5	21.4	DR 4.0	DR 4.5	DR 78.8	-----			
SC 4.5					SC 5.0	SC 96.5	1.56				
DR/SC05000	1/4	330	25.0	40.0	DR 6.0	DR 7.0	DR 130.	-----			
SC 7.5					SC 8.5	SC 163.	2.95				



Output Torque of DR Double Acting Type(Nm)

TYPE	2.5bar	3.0bar	3.5bar	4.0bar	4.5bar	5.0bar	5.5bar	6.0bar	7.0bar	8.0bar
DR00006										
DR00015	8.3	10.0	11.6	13.3	15.0	16.6	18.3	19.9	23.3	26.6
DR00030	14.7	17.6	20.5	23.5	26.4	29.3	32.2	35.2	41.0	46.9
DR00060	29.1	34.9	40.7	46.5	52.3	58.2	64.0	69.8	81.4	93.0
DR00100	45.7	54.9	64.0	73.2	82.3	91.5	101	110	128	146
DR00150	66.5	79.7	93.0	106	120	133	146	160	186	213
DR00220	107	129	150	172	193	215	236	258	301	344
DR00300	138	166	194	221	249	277	304	332	387	443
DR00450	217	261	304	348	391	434	478	521	608	695
DR00600	283	340	397	453	510	567	623	680	793	907
DR00900	383	459	536	612	689	765	842	918	1071	1224
DR01200	531	638	744	850	956	1063	1169	1275	1488	1700
DR02000	935	1122	1309	1496	1683	1870	2057	2244	2618	2992
DR03000	1347	1617	1886	2156	2425	2695	2964	3234	3772	4311
DR05000	2350	2821	3291	3761	4231	4701	5171	5641	6581	7521
DR10000										

Output Torque of SC Single Acting Type(Nm)

TYPE	Spring Quantity	Air Pressure Torque																		Spring Torque					
		2.5bar		3.0bar		3.5bar		4.0bar		4.5bar		5.0bar		5.5bar		6.0bar		7.0bar		8.0bar		90° Start	0° End		
		0° Start	90° End	0° Start	90° End	0° Start	90° End	0° Start	90° End	0° Start	90° End	0° Start	90° End	0° Start	90° End	0° Start	90° End	0° Start	90° End	0° Start	90° End	90° Start	0° End		
SC00015	05	4.9	3.4	6.6	5.1	8.2	6.8	9.9	8.4	11.6	10.1	13.2	11.7									4.9	3.4		
	06	4.2	2.5	5.9	4.1	7.6	5.8	9.2	7.4	10.9	9.1	12.5	10.8	14.2	12.4								5.8	4.1	
	07			5.2	3.2	6.9	4.8	8.5	6.5	10.2	8.1	11.9	9.8	13.5	11.5	15.2	13.1						6.8	4.7	
	08					6.2	3.8	7.9	5.5	9.5	7.2	11.2	8.8	12.8	10.5	14.5	12.1	17.8	15.5					7.8	5.4
	09							7.2	4.5	8.9	6.2	10.5	7.8	12.2	9.5	13.8	11.2	17.2	14.5	20.5	17.8			8.8	6.1
	10									8.2	5.2	9.8	6.9	11.5	8.5	13.2	10.2	16.5	13.5	19.8	16.8			9.7	6.8
	11											9.2	5.9	10.8	7.6	12.5	9.2	15.8	12.5	19.1	15.9			10.7	7.4
12													10.1	6.6	11.8	8.2	15.1	11.6	18.4	14.9			11.7	8.1	
SC00030	05	9.1	6.2	12	9.1	15	12	17.9	15	20.8	17.9	23.7	20.8										8.5	5.5	
	06	8	4.5	10.9	7.4	13.8	10.3	16.8	13.3	19.7	16.2	22.6	19.1	25.6	22.1								10.2	6.7	
	07			9.8	5.7	12.7	8.7	15.7	11.6	18.6	14.5	21.5	17.4	24.5	20.4	27.4	23.3							11.8	7.8
	08					11.6	7	14.6	9.9	17.5	12.8	20.4	15.8	23.3	18.7	26.3	21.6	32.1	27.5					13.5	8.9
	09							13.4	8.2	16.4	11.1	19.3	14.1	22.2	17	25.2	19.9	31	25.8	36.9	31.6			15.2	10
	10									15.3	9.4	18.2	12.4	21.1	15.3	24.1	18.2	29.9	24.1	35.8	29.9			16.9	11.1
	11											17.1	10.7	20	13.6	22.9	16.5	28.8	22.4	34.7	28.2			18.6	12.2
12													18.9	11.9	21.8	14.8	27.7	20.7	33.5	26.6			20.3	13.3	
SC00060	05	18	11.7	23.8	17.6	29.6	23.4	35.4	29.2	41.2	35	47.1	40.8										17.3	11.1	
	06	15.8	8.3	21.6	14.1	27.4	19.9	33.2	25.7	39	31.5	44.8	37.3	50.7	43.2								20.8	13.3	
	07			19.4	10.6	25.2	16.4	31	22.3	36.8	28.1	42.6	33.9	48.4	39.7	54.3	45.5							24.2	15.5
	08					23	13	28.8	18.8	34.6	24.6	40.4	30.4	46.2	36.2	52	42	63.7	53.7					27.7	17.7
	09							26.6	15.3	32.4	21.1	38.2	27	44	32.8	49.8	38.6	61.5	50.2	73.1	61.8			31.1	19.9
	10									30.2	17.7	36	23.5	41.8	29.3	47.6	35.1	59.2	46.7	70.9	58.4			34.6	22.1
	11											33.8	20	39.6	25.8	45.4	31.7	57	43.3	68.7	54.9			38.1	24.3
12													37.4	22.4	43.2	28.2	54.8	39.8	66.4	51.4			41.5	26.5	
SC00100	05	27.4	16.8	36.5	26	45.7	35.1	54.8	44.3	63.9	53.4	73.1	62.6										28.9	18.3	
	06	23.7	11.1	32.8	20.2	42	29.3	51.1	38.5	60.3	47.6	69.4	56.8	78.6	65.9								34.7	22	
	07			29.2	14.4	38.3	23.6	47.5	32.7	56.6	41.9	65.7	51	74.9	60.1	84	69.3						40.4	25.7	
	08					34.6	17.8	43.8	26.9	52.9	36.1	62.1	45.2	71.2	54.4	80.4	63.5	98.6	81.8					46.2	29.4
	09							40.1	21.2	49.3	30.3	58.4	39.5	67.5	48.6	76.7	57.7	95	76	113	94.3			52	33
	10									45.6	24.5	54.7	33.7	63.9	42.8	73	52	91.3	70.2	110	88.5			57.8	36.7
	11											51.1	27.9	60.2	37	69.3	46.2	87.6	64.5	106	82.8			63.5	40.4
12													56.5	31.3	65.7	40.4	84	58.7	102	77			69.3	44	
SC00150	05	41.1	27	54.4	40.3	67.7	53.6	81	66.8	94.2	80.1	108	93.4										39.4	25.3	
	06	36.1	19.1	49.3	32.4	62.6	45.7	75.9	58.9	89.2	72.2	103	85.5	116	98.8								47.3	30.4	
	07			44.3	24.5	57.6	37.8	70.8	51.1	84.1	64.3	97.4	77.6	111	90.9	124	104						55.2	35.4	
	08					52.5	29.9	65.8	43.2	79.1	56.5	92.3	69.7	106	83	119	96.3	146	123					63.1	40.5
	09							60.7	35.3	74	48.6	87.3	61.9	101	75.1	114	88.4	140	115	167	142			71	45.5
	10									68.9	40.7	82.2	54	95.5	67.3	109	80.5	135	107	162	134			78.8	50.6
	11											77.2	46.1	90.5	59.4	104	72.7	130	99	157	126			86.7	55.6
12													85.4	51.5	98.7	64.8	125	92	152	118			94.6	60.7	
SC00220	05	63.3	41.8	87.8	63.3	109	84.7	131	106	152	128	174	149										65.6	41	
	06	58.1	28.7	79.6	50.1	101	71.6	123	93.1	144	115	165	136	187	158								78.7	49.3	
	07			71.3	37	92.8	58.5	114	80	136	101	157	123	179	144	200	166						91.8	57.5	
	08					84.6	45.4	106	66.9	128	88.3	149	110	171	131	192	153	235	196					105	65.7
	09							97.9	53.8	119	75.2	141	96.7	162	118	184	140	227	183	270	226			118	74
	10									111	62.1	133	83.6	154	105	176	127	219	170	261	212			131	82
	11											124	70.5	146	92	167	113	210	156	253	199			144	90.3
12													138	78.8	159	100	202	143	245	186			157	98.5	



Configuration and Connection Size(mm)

ISO5211 / VDI/VDE3845

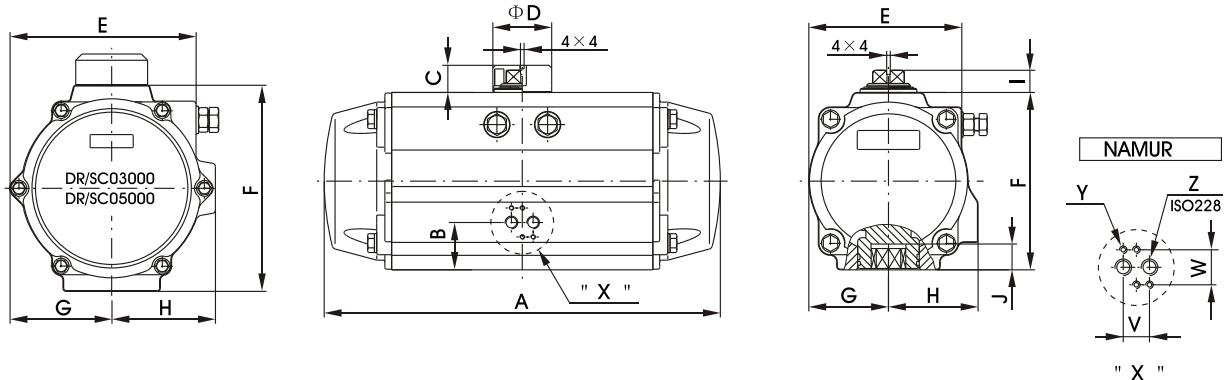

Connection Size of DR/SC05000

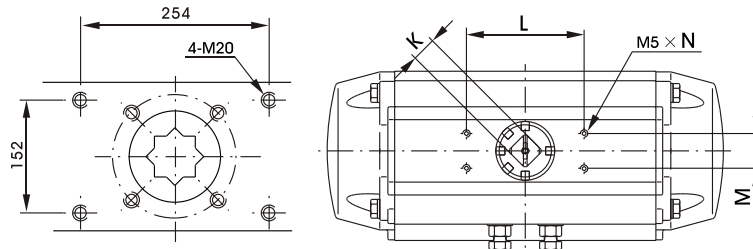

LD: Parallel Bevel

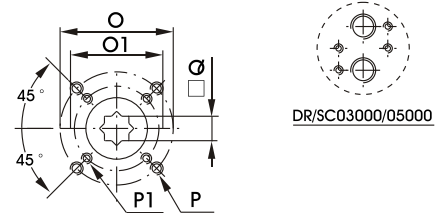

Bottom View

TYPE	00015	00030	00060	00100	00150	00220	00300	00450	00600	00900	01200	02000	03000	05000
	DR/SC	DR/SC	DR/SC	DR/SC	DR/SC	DR/SC	DR/SC	DR/SC	DR/SC	DR/SC	DR/SC	DR/SC	DR/SC	DR/SC
ISOflange	F04	F05	F05-07	F05-07	F07-10	F07-10	F07-10	F10-12	F10-12	F12	F14	F16	F16	F16
A	140.5	158.5	210.5	247.5	268.5	315	345	408.5	437.5	487	543	633	728	876
B	26.5	30	30.5	32.5	37.5	42.5	45	47.5	52	58.5	62.5	78.5	165	187
C	20	20	20	20	20	30	30	30	30	50	50	50	50	50
ΦD	40	40	40	40	40	56	56	65	65	80	80	115	115	115
E	59	72	84.5	97.5	111	127	136	156.5	169	190.5	213	251	298.5	383
F	69	85	102	115	127	145	157	177	196	220.5	245	298.5	330	405
G	29	36	42.5	49.5	56	64	69.5	80	88	99	110	131	163.5	201
H	41.5	47	52	56.8	67	77	82	91.5	99	105	112	131	166	204.5
I	14.5	14.5	14.5	14.5	14.5	24.5	24.5	24.5	24.5	44.5	44.5	44.5	44.5	44.5
Jmlm	12	16	16	19	19	24	24	29	29	29	38	38	48	57
K	11	11	17	17	17	27	27	27	27	36	36	36	36	36
L	80	80	80	80	80	80	80	80	80	130	130	130	130	130
M	30	30	30	30	30	30	30	30	30	30	30	30	30	30
N	4	8	8	8	8	8	8	8	8	8	8	8	8	8
$\Phi O1$	42	50	50	50	70	70	70	102	102	125	140	165	165	165
ΦO	---	---	70	70	102	102	102	125	125	---	---	---	---	---
P1	4-M6	4-M6	4-M6	4-M6	4-M8	4-M8	4-M8	4-M10	4-M10	4-M12	4-M16	4-M20	4-M20	4-M20
P	---	---	4-M8	4-M8	4-M10	4-M10	4-M10	4-M12	4-M12	---	---	---	---	---
Q	11	14	14	17	17	22	22	27	27	27	36	36	46	55
V	24	24	24	24	24	24	24	24	24	24	24	40	40	40
W	32	32	32	32	32	32	32	32	32	32	32	45	45	45
Y	M5x8	M5x8	M5x8	M5x8	M5x8	M5x8	M5x8	M5x8	M5x8	M5x8	M5x8	M6x10	M6x10	M6x10
Z	1/8 "	1/8 "	1/8 "	1/8 "	1/4 "	1/4 "	1/4 "	1/4 "	1/4 "	1/4 "	1/4 "	3/8 "	1/2 "	1/2 "



Connection Size of Delivery Outlet (customized)

H: Parallel Subtense

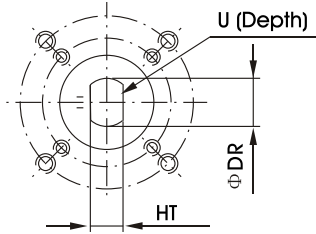

Bottom View

W: Two Key Grooves

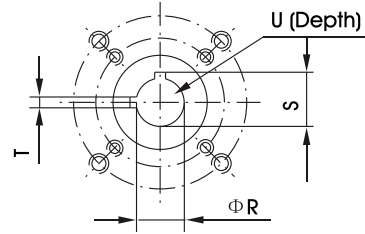

Bottom View

PS: could be customized as require

TYPE	00015	00030	00060	00100	00150	00220	00300	00450	00600	00900	01200	02000	03000	05000
	DR/SC	DR/SC	DR/SC	DR/SC	DR/SC	DR/SC	DR/SC	DR/SC	DR/SC	DR/SC	DR/SC	DR/SC	DR/SC	DR/SC
ΦR	12.7	12.7	12.7	15.88	19.05	22.23	22.23	28.58	28.58	31.75	31.75	33.34	38.1	41.28
S	14.2	14.2	14.2	18.4	21.6	24.8	24.8	32.1	32.1	35.3	35.3	37.4	42.4	45.3
T	3	3	5	5	5	5	5	8	8	8	8	10	10	12
U	32	32	32	32	32	45	45	45	45	45	45	51	51	65
ΦDR	13	13	13	16.1	19.2	22.4	22.4	28.8	28.8	32	32	33.6	38.4	41.5
HT	10	10	10	12	14	17	17	22	22	24	24	27	27	32

Full Stroke Modulating And Limiting Actuator

Special adjusting banking screws are provided at the two ends of the new type pneumatic actuator. The actuator can be adjusted at the range between 0°~90°, 0°~120° or 0°~180°. Full stroke adjustment could be applied to all series of actuators.

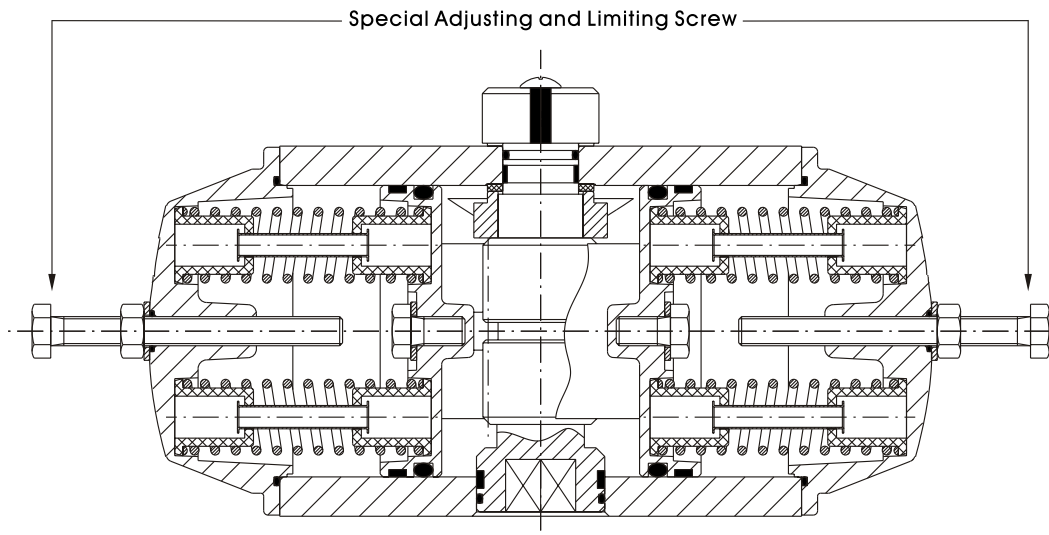



Configuration And Connection Size of 120°/180° Stroke Actuator(double acting)

ISO5211 / VDI/VDE3845

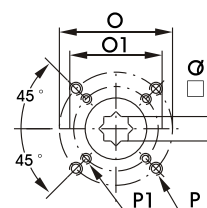
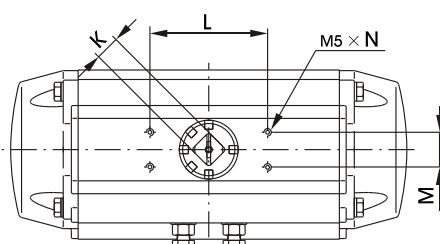
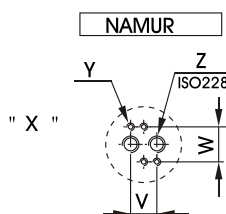
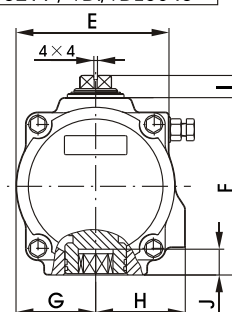
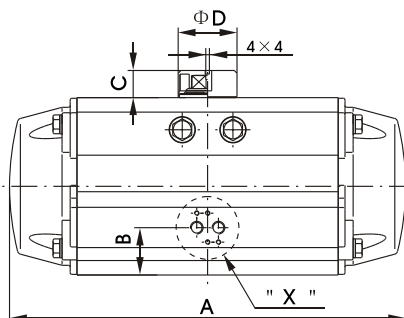

1. Actuators of other types could be provided as customer requires
2. Actuators with different stroke type could be provided, such as 140° or 160° stroke.

TYPE	00015	00030	00060	00100	00150	00220	00300	00450	00600	00900	01200	02000	03000	05000
	DR	DR	DR	DR	DR	DR	DR	DR	DR	DR	DR	DR	DR	DR
ISOflange	—	F05	F05-07	—	F07-10	—	F07-10	—	F10-12	—	F14	—	—	—
A(120°)	—	183	243	—	309	—	397	—	504	—	622	—	—	—
A(180°)	—	225	305	—	385	—	498	—	630	—	775	—	—	—
B	—	30	30.5	—	37.5	—	45	—	52	—	62.5	—	—	—
C	—	20	20	—	20	—	30	—	30	—	50	—	—	—
ΦD	—	40	40	—	40	—	56	—	65	—	80	—	—	—
E	—	72	84.5	—	111	—	136	—	169	—	213	—	—	—
F	—	85	102	—	127	—	157	—	196	—	245	—	—	—
G	—	36	42.5	—	56	—	69.5	—	88	—	110	—	—	—
H	—	47	52	—	67	—	82	—	99	—	112	—	—	—
I	—	14.5	14.5	—	14.5	—	24.5	—	24.5	—	44.5	—	—	—
Jmm	—	16	16	—	19	—	24	—	29	—	38	—	—	—
K	—	11	17	—	17	—	27	—	27	—	36	—	—	—
L	—	80	80	—	80	—	80	—	80	—	130	—	—	—
M	—	30	30	—	30	—	30	—	30	—	30	—	—	—
N	—	8	8	—	8	—	8	—	8	—	8	—	—	—
ΦO1	—	50	50	—	70	—	70	—	102	—	140	—	—	—
ΦO	—	---	70	—	102	—	102	—	125	—	---	—	—	—
P1	—	4-M6	4-M6	—	4-M8	—	4-M8	—	4-M10	—	4-M16	—	—	—
P	—	---	4-M8	—	4-M10	—	4-M10	—	4-M12	—	---	—	—	—
□Q	—	14	14	—	17	—	22	—	27	—	36	—	—	—
ΦR	—	—	—	—	—	—	—	—	—	—	—	—	—	—
S	—	—	—	—	—	—	—	—	—	—	—	—	—	—
T	—	—	—	—	—	—	—	—	—	—	—	—	—	—
U	—	—	—	—	—	—	—	—	—	—	—	—	—	—
V	—	24	24	—	24	—	24	—	24	—	24	—	—	—
W	—	32	32	—	32	—	32	—	32	—	32	—	—	—
Y	—	M5x8	M5x8	—	M5x8	—	M5x8	—	M5x8	—	M5x8	—	—	—
Z	—	1/8"	1/8"	—	1/4"	—	1/4"	—	1/4"	—	1/4"	—	—	—



3-position Pneumatic Actuator

Two types of 3-position pneumatic actuators can be provided, namely 0°-45°-90° type and 0°-90°-180° type respectively. After the air comes into the cylinder from the air entrance " 2 ", the pistons' movements toward the ends would be limited by the auxiliary pistons mechanism. Thus the pistons would stay in the middle position. The position of the mid position could be adjust to 20°, 30°, 50°, 75° and 95°, 120°, 130°, 150°, 175° etc by using the adjusting screws at each end of the surface.



Operating Principles:

The control circuit with solenoid valve is designed to complete the operation of 3-position pneumatic actuator. The control principles are as followed.

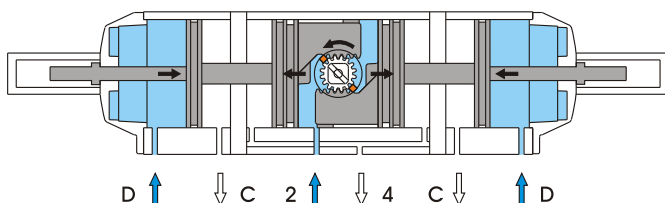

Position 1 (mid position)

Air source pressure come into both entrance 2 and entrance D simultaneously and press out the air from entrance 4 and C. The inner pistons move along Entrance 2 while the inner pistons are limited in the mid position which is decided before by the auxiliary pistons mechanism through entrance D.

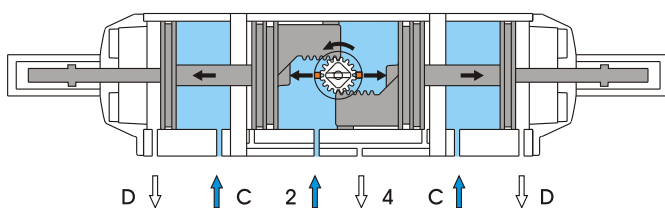

Position 2 (complete open position)

Air source pressure come into both entrance 2 and entrance C simultaneously and press out the air from entrance 4 and D. The inner pistons in entrance 2 keeps moving while the lock of auxiliary pistons mechanism is released through entrance C and the inner pistons reach complete open position.

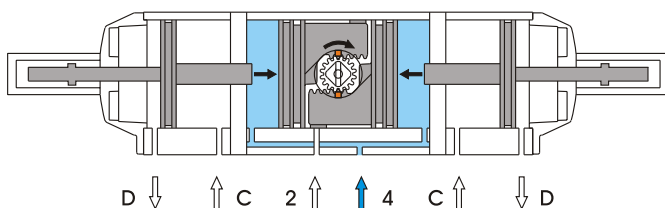

Position 3 (complete close position)

Air source pressure come into entrance 4 and press out the air from entrance 2. The inner pistons move toward midposition to reach complete close position. Springs with 3 different reset type, namely 0°-45°-90° are provided. When air supply or power supply are cut off (or when air source fails), the springs would force the inner pistons to move to the complete close position.

DR/SC 3-Position Pneumatic Actuator

0°-45°-90°/0°-90°-180°

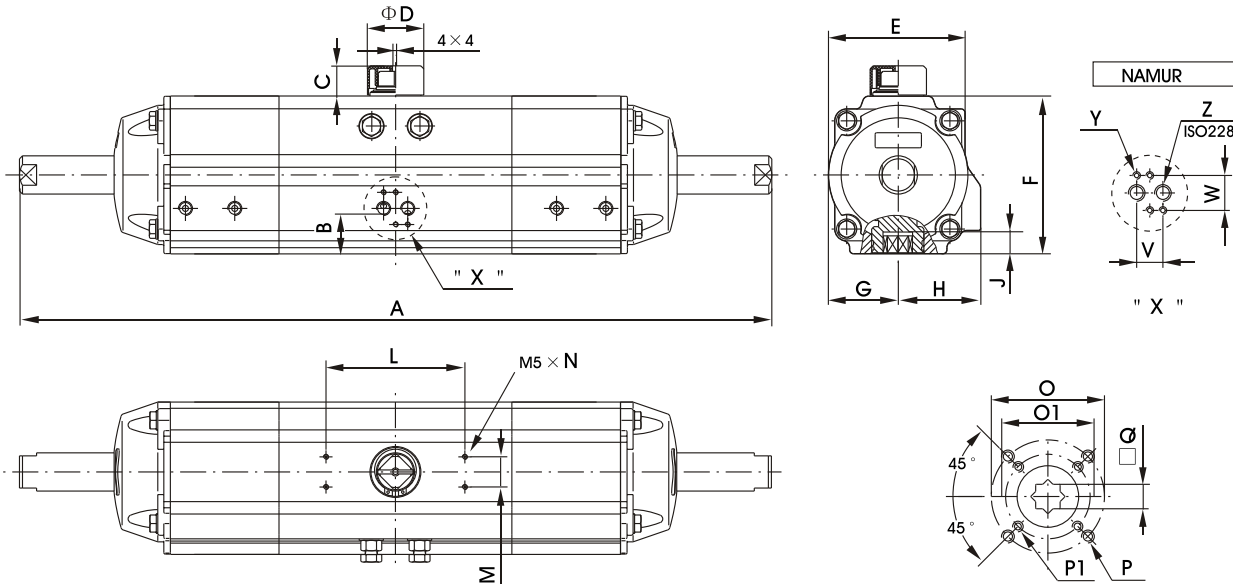

Configuration And Connection Size(mm)

TYPE	A		B	C	ΦD	E	F	G	H	J	L	M	N	O1	O	P1	P	□Q	V	W	Y	Z
	0°-45°-90°	0°-90°-180°																				
DRSC00030	390	440	30	20	40	72	85	36	47	16	80	30	8	50	—	4-M6	—	14	24	32	M5×8	1/8"
DRSC00060	480	570	30.5	20	40	84.5	102	42.5	52	16	80	30	8	50	70	4-M6	4-M8	14	24	32	M5×8	1/8"
DRSC00150	600	710	37.5	20	40	111	127	56	67	19	80	30	8	70	102	4-M8	4-M10	17	24	32	M5×8	1/4"
DRSC00300	720	910	45	30	56	136	157	69.5	82	24	80	30	8	70	102	4-M8	4-M10	22	24	32	M5×8	1/4"
DRSC00600	915	1130	52	30	65	169	196	88	99	29	80	30	8	102	125	4-M10	4-M12	27	24	32	M5×8	1/4"
DRSC01200	1155	1400	62.5	50	80	213	245	110	112	38	130	30	8	140	—	4-M16	—	36	24	32	M5×8	1/4"

Output Torque of DR Double Acting Type(Nm)

TYPE	2.5bar	3.0bar	3.5bar	4.0bar	4.5bar	5.0bar	5.5bar	6.0bar	7.0bar	8.0bar
DR00030	14.7	17.6	20.5	23.5	26.4	29.3	32.2	35.2	41.0	46.9
DR00060	29.1	34.9	40.7	46.5	52.3	58.2	64.0	69.8	81.4	93.0
DR00150	66.5	79.7	93.0	106	120	133	146	160	186	213
DR00300	138	166	194	221	249	277	304	332	387	443
DR00600	283	340	397	453	510	567	623	680	793	907
DR01200	531	638	744	850	956	1063	1169	1275	1488	1700

SC 0°-45°-90° Single Acting Output Torque (spring resets) (Nm)

TYPE	Spring Quantity	Air Pressure Torque																Spring Torque					
		2.5bar		3.0bar		3.5bar		4.0bar		4.5bar		5.0bar		5.5bar		6.0bar		7.0bar		8.0bar		90° Start	0° End
		0° Start	90° End	0° Start	90° End	0° Start	90° End	0° Start	90° End	0° Start	90° End	0° Start	90° End	0° Start	90° End	0° Start	90° End	0° Start	90° End				
SC00030	05	9.1	6.2	12	9.1	15	12	17.9	15	20.8	17.9	23.7	20.8									8.5	5.5
	06	8	4.5	10.9	7.4	13.8	10.3	16.8	13.3	19.7	16.2	22.6	19.1	25.6	22.1							10.2	6.7
	07			9.8	5.7	12.7	8.7	15.7	11.6	18.6	14.5	21.5	17.4	24.5	20.4	27.4	23.3					11.8	7.8
	08					11.6	7	14.6	9.9	17.5	12.8	20.4	15.8	23.3	18.7	26.3	21.6	32.1	27.5			13.5	8.9
	09							13.4	8.2	16.4	11.1	19.3	14.1	22.2	17	25.2	19.9	31	25.8	36.9	31.6	15.2	10
	10									15.3	9.4	18.2	12.4	21.1	15.3	24.1	18.2	29.9	24.1	35.8	29.9	16.9	11.1
	11											17.1	10.7	20	13.6	22.9	16.5	28.8	22.4	34.7	28.2	18.6	12.2
	12													18.9	11.9	21.8	14.8	27.7	20.7	33.5	26.6	20.3	13.3
SC00060	05	18	11.7	23.8	17.6	29.6	23.4	35.4	29.2	41.2	35	47.1	40.8									17.3	11.1
	06	15.8	8.3	21.6	14.1	27.4	19.9	33.2	25.7	39	31.5	44.8	37.3	50.7	43.2							20.8	13.3
	07			19.4	10.6	25.2	16.4	31	22.3	36.8	28.1	42.6	33.9	48.4	39.7	54.3	45.5					24.2	15.5
	08					23	13	28.8	18.8	34.6	24.6	40.4	30.4	46.2	36.2	52	42	63.7	53.7			27.7	17.7
	09							26.6	15.3	32.4	21.1	38.2	27	44	32.8	49.8	38.6	61.5	50.2	73.1	61.8	31.1	19.9
	10									30.2	17.7	36	23.5	41.8	29.3	47.6	35.1	59.2	46.7	70.9	58.4	34.6	22.1
	11											33.8	20	39.6	25.8	45.4	31.7	57	43.3	68.7	54.9	38.1	24.3
	12													37.4	22.4	43.2	28.2	54.8	39.8	66.4	51.4	41.5	26.5
SC00150	05	41.1	27	54.4	40.3	67.7	53.6	81	66.8	94.2	80.1	108	93.4									39.4	25.3
	06	36.1	19.1	49.3	32.4	62.6	45.7	75.9	58.9	89.2	72.2	103	85.5	116	98.8							47.3	30.4
	07			44.3	24.5	57.6	37.8	70.8	51.1	84.1	64.3	97.4	77.6	111	90.9	124	104					55.2	35.4
	08					52.5	29.9	65.8	43.2	79.1	56.5	92.3	69.7	106	83	119	96.3	146	123			63.1	40.5
	09							60.7	35.3	74	48.6	87.3	61.9	101	75.1	114	88.4	140	115	167	142	71	45.5
	10									68.9	40.7	82.2	54	95.5	67.3	109	80.5	135	107	162	134	78.8	50.6
	11											77.2	46.1	90.5	59.4	104	72.7	130	99	157	126	86.7	55.6
	12													85.4	51.5	98.7	64.8	125	92	152	118	94.6	60.7
SC00300	05	85.9	55.9	114	84	141	111	169	139	197	167	224	194									82.5	52.5
	06	75.4	39.4	103	67	131	95	158	122	186	150	214	178	241	205							98.9	62.9
	07			92.6	50.6	120	78	148	106	176	134	203	161	231	189	259	217					115	73.4
	08					110	62	137	89.4	165	117	193	145	221	173	248	200	304	256			132	83.9
	09							127	72.9	155	101	182	128	210	156	238	184	293	239	348	294	148	94.4
	10									144	84	172	112	200	140	227	167	283	223	338	278	165	105
	11											161	95.3	189	123	217	151	272	206	327	261	181	115
	12													179	107	206	134	262	190	317	245	198	126
SC00600	05	171	117	228	174	285	231	341	287	398	344	455	401									166	112
	06	149	84	206	141	262	197	319	254	376	311	432	367	489	424							199	135
	07			183	108	240	164	296	221	353	278	410	334	466	391	523	448					233	157
	08					217	131	274	188	331	244	387	301	444	358	501	414	614	528			266	179
	09							252	154	308	211	365	268	422	324	478	381	592	494	705	608	299	202
	10									286	178	343	235	399	291	456	348	569	461	683	575	332	224
	11											320	201	377	258	433	315	547	428	660	541	365	247
	12													354	225	411	281	524	395	638	508	399	269
SC01200	05	319	216	425	323	532	429	638	535	744	641	850	748									315	212
	06	277	153	383	260	489	366	595	472	702	578	808	685	914	791							378	255
	07			340	197	447	303	553	409	659	515	765	622	872	728	978	834					441	297
	08					404	240	510	346	617	452	723	559	829	665	935	771	1148	984			504	340
	09							468	283	574	389	680	496	787	602	893	708	1105	921	1318	1133	567	382
	10									532	326	638	433	744	539	850	645	1063	858	1275	1070	630	425
	11											595	370	702	476	808	582	1020	795	1233	1007	693	467
	12													659	413	766	519	978	732	1191	944	756	510

■ The darkened recommendation index under the air pressure torque are in accordance with the spring return torque datas and the spring number.



180°Stroke Single Acting Actuator (spring reset)

Spring subassembly are provided at each end of 180°spring reset type pneumatic actuator which is suitable to act the back-and-forth movement among 0°-90°-180°and comes back to the position of 90°by spring resetting when air source pressure drops (or fails).

The 180° full -open position and the 0° shut-up position can be made for precious external adjustment at $\pm 4^\circ$ via standard methods.



Control Principle

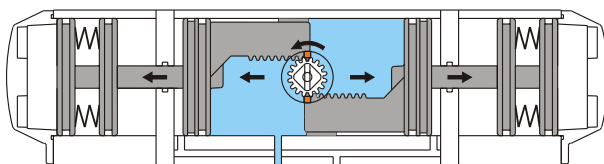

"2" ↑ ↓ "4"

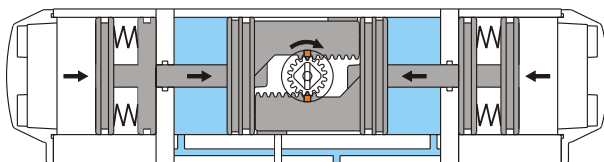

"2" ↓ ↑ "4"

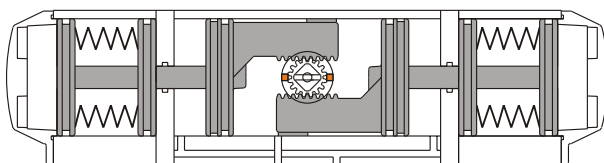

"2" ↓ ↓ "4"

From 90° to 180°

The air source pressure comes into the cylinder body between the two pistons from air entrance (2) and pushes the pistons toward the end of the cylinder body. The spring subassembly at each end is forced to shrink while the air between the pistons and the ends of the cylinder body is released from air entrance (4). Meanwhile the racks of pistons drive the output shaft (gear wheel) simultaneously to rotate anticlockwise to 180°.

From 90° to 0°

The air source pressure comes into the cylinder body between the two pistons from air entrance (4) and pushes the pistons toward each other. The spring subassembly at each end begins to reset while the air between the pistons is released from air entrance (2). Meanwhile the racks of pistons rotate the output shaft (gear wheel) clockwise simultaneously to 0°.

Air fail Operation

When the position is at 180°: when the air source pressure of entrance (2) is lost or the power supply of the solenoid valve is cut, the springs force the pistons to move toward the middle of the cylinder body which would rotate the output shaft clockwise to position of 90°.

When the position is at 0°: when the air source pressure of entrance (4) is lost or the power supply of the solenoid valve is cut, the springs force the pistons to move toward the end of the cylinder body which would rotate the output shaft anticlockwise to position of 90°.



Control Principle

In order to control the operation of the actuators 180° with 90° fail safe position, a system of solenoid valves controlling a sequence of air supplies to the actuator is required as described besides.

The actuator may be controlled by two 3/2 way solenoid valves or by one 5/3 way solenoid valve.

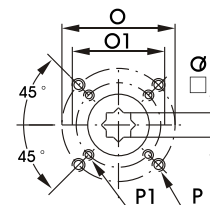
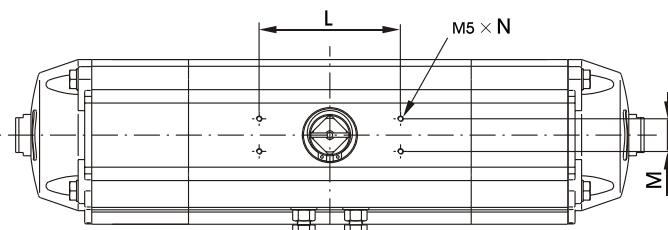
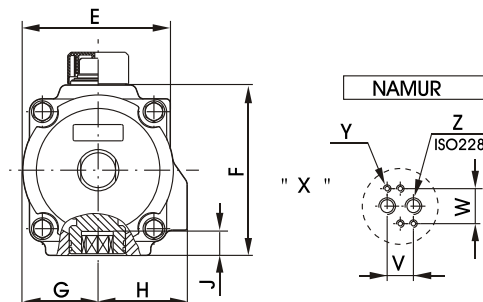
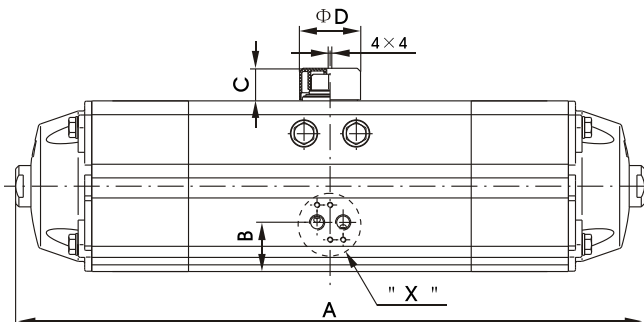
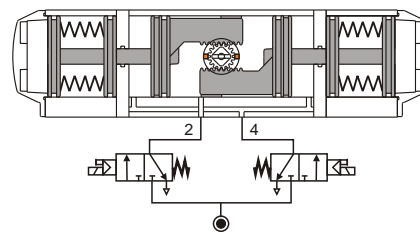

Configuration and Connection Size(mm)

TYPE																					
	A	B	C	ΦD	E	F	G	H	J	L	M	N	O1	O	P1	P	□Q	V	W	Y	Z
SC00150	630	37.5	20	40	111	127	56	67	19	80	30	8	70	102	4-M8	4-M10	17	24	32	M5×8	1/4"
SC00300	812	45	30	56	136	157	69.5	82	24	80	30	8	70	102	4-M8	4-M10	22	24	32	M5×8	1/4"
SC00600	1007	52	30	65	169	196	88	99	29	80	30	8	102	125	4-M10	4-M12	27	24	32	M5×8	1/4"
SC01200	1242	62.5	50	80	213	245	110	112	38	130	30	8	140	—	4-M16	—	36	24	32	M5×8	1/4"

Output Torque

TYPE	Spring Quantity	Air Pressure Torque																Spring Torque					
		2.5bar		3.0bar		3.5bar		4.0bar		4.5bar		5.0bar		5.5bar		6.0bar				7.0bar		8.0bar	
		0° and 90°	180°	0° and 90°	180°	0° and 90°	180°	0° and 90°	180°	0° and 90°	180°	0° and 90°	180°	0° and 90°	180°	0° and 90°	180°	0° and 90°	180°	0° and 90°	180°	0° and 90°	180°
SC00150	06	36.1	19.1	49.3	32.4	62.6	45.7	75.9	58.9	89.2	72.2	103	85.5	116	98.8							47.3	30.4
	08					52.5	29.9	65.8	43.2	79.1	56.5	92.3	69.7	106	83	119	96.3	146	123			63.1	40.5
	10									68.9	40.7	82.2	54	95.5	67.3	109	80.5	135	107	162	134	78.8	50.6
	12													85.4	51.5	98.7	64.8	125	92	152	118	94.6	60.7
SC00300	06	75.4	39.4	103	67	131	95	158	122	186	150	214	178	241	205							98.9	62.9
	08					110	62	137	89.4	165	117	193	145	221	173	248	200	304	256			132	83.9
	10									144	84	172	112	200	140	227	167	283	223	338	278	165	105
	12													179	107	206	134	262	190	317	245	198	126
SC00600	06	149	84	206	141	262	197	319	254	376	311	432	367	489	424							199	135
	08					217	131	274	188	331	244	387	301	444	358	510	414	614	528			266	179
	10									286	178	343	235	399	291	456	348	569	461	683	575	332	224
	12													354	225	411	281	524	395	638	508	399	269
SC01200	06	277	153	383	260	489	366	595	472	702	578	808	685	914	791							378	255
	08					404	240	510	346	617	452	723	559	829	665	935	771	1148	984			504	340
	10									532	326	638	433	744	539	850	645	1063	858	1275	1070	630	425
	12													659	413	766	519	978	732	1191	944	756	510



Standard Solenoid Valve
Could Be Provided
VDI/VDE3845、NAMUR



Standard Switch Cabinet
Could Be Provided
VDI/VDE 3845



Standard Valve Positioner
Could Be Provided
VDI/VDE3845



Manual Clutch Could Be Provided



Pneumatic Ball Valve
Pneumatic Butterfly Valve

